



MCS206/C/GL/8 BAY UNITS

CODING METHOD

PRODUCT CODE	FIXING METHOD	SLAT MATERIAL	METAL FINISH	NUMBER OF BAYS
MCS206	C		GL	8

* Technical drawings not to scale

NOTE-

- Site Engineer to determine suitable fixing method.
- Fixing bolts by others - 14 mm dia. holes (use M12 bolts).
- Size of concrete foundation and concrete mix to be determined on site taking ground conditions into account.
- Number of bays can be matched to cycle parking requirements, specify in coding method.
- Roof covering in 10 mm Twin wall opaque polycarbonate.
- Cycle rack shown is the Malford MCR201/10 bike/bay.

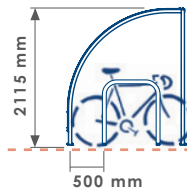
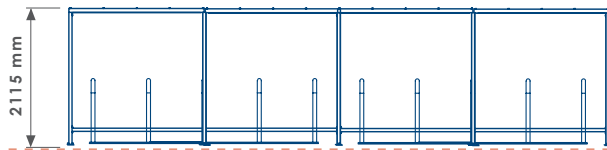
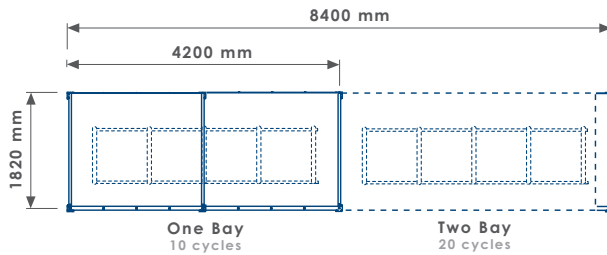

FINISHED GRADE

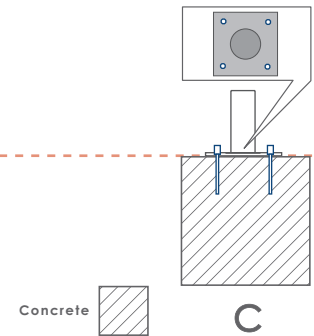

MALFORD CYCLE SHELTER MCS206

PRODUCT DIMENSIONS	HEIGHT	2115 mm	LENGTH/BAY	4200 mm	WIDTH	1820 mm	WEIGHT/BAY	180 Kg	CAPACITY		SEAT HEIGHT		OTHER	
--------------------	--------	---------	------------	---------	-------	---------	------------	--------	----------	--	-------------	--	-------	--

FIXING OPTION	Direct Embedment/Root Fix	A	
	Below Finished Grade Base Fix	B	
	Surface Mount	C	<input checked="" type="checkbox"/>
	Plinth Mount - Buff Exposed Aggregate	D-BEA	
	Plinth Mount - Buff Granite	D-BG	
	Plinth Mount - Grey Granite	D-GG	
	Free Standing	FS	
	Free Standing with Base Weight	FS-BW	
	Wall Mount	WM	
	Non Standard	NS	
To BREEAM Standard	B06/B08		

SLAT MATERIAL	Treated Redwood Class 3 Unstained	TRC3	
	Treated Redwood Class 3 Stained Dark Oak	TRC3-DO	
	Treated Redwood Class 4 Unstained	TRC4	
	Treated Redwood Class 4 Stained Dark Oak	TRC4-DO	
	Treated Softwood Unstained	TS	
	Douglas Fir	DF	
	FSC Hardwood Iroko	HI	
	Recycled Plastic - Black	RP-BK	
	Recycled Plastic - Grey	RP-GY	
	Recycled Plastic - Green	RP-GN	
Recycled Plastic - Brown	RP-BR		

METAL FINISH	Aluminium Powder Coated	APC		
	Galvanised	GL	<input checked="" type="checkbox"/>	
	Galvanised and Powder Coated	GPC	<input checked="" type="checkbox"/>	
	Zinc Plated and Powder Coated	PPC		
	Stainless Steel	SS-304/316		
	TOP TYPE	Apex Top	AT	
		Chamfer Top	CT	
		Dome Top	DT	
		Flat Top	FT	
		Open Top	OT	
Slant Top	ST			

CONCRETE COLOUR	Concrete Colour - Light Grey	LG		
	Concrete Colour - White	WT		
	Concrete Colour - Buff	BF		
	Concrete Colour - Black	BK		
	Concrete Colour - Red	RD		
	Concrete Colour - Standard Grey	SG		
	Concrete Colour - Non Standard	NS		
	FINISH	Concrete Finish - Dressed Finish	DS	
		Concrete Finish - Satin Shine	SH	
		Concrete Finish - Deluxe Polish (top)	DP	
Concrete Finish - Textured Finish	TF			